

## UB4 SERIES GOLD LINE SHOT PIN

USE AS: RETRACTABLE LOCATING PINS, PART STOPS, PROBE SLIDES, WEDGE LOCKS, STRAIGHT CLAMP, LARGE PART METERS

**NO LUBRICATION  
REQUIRED**

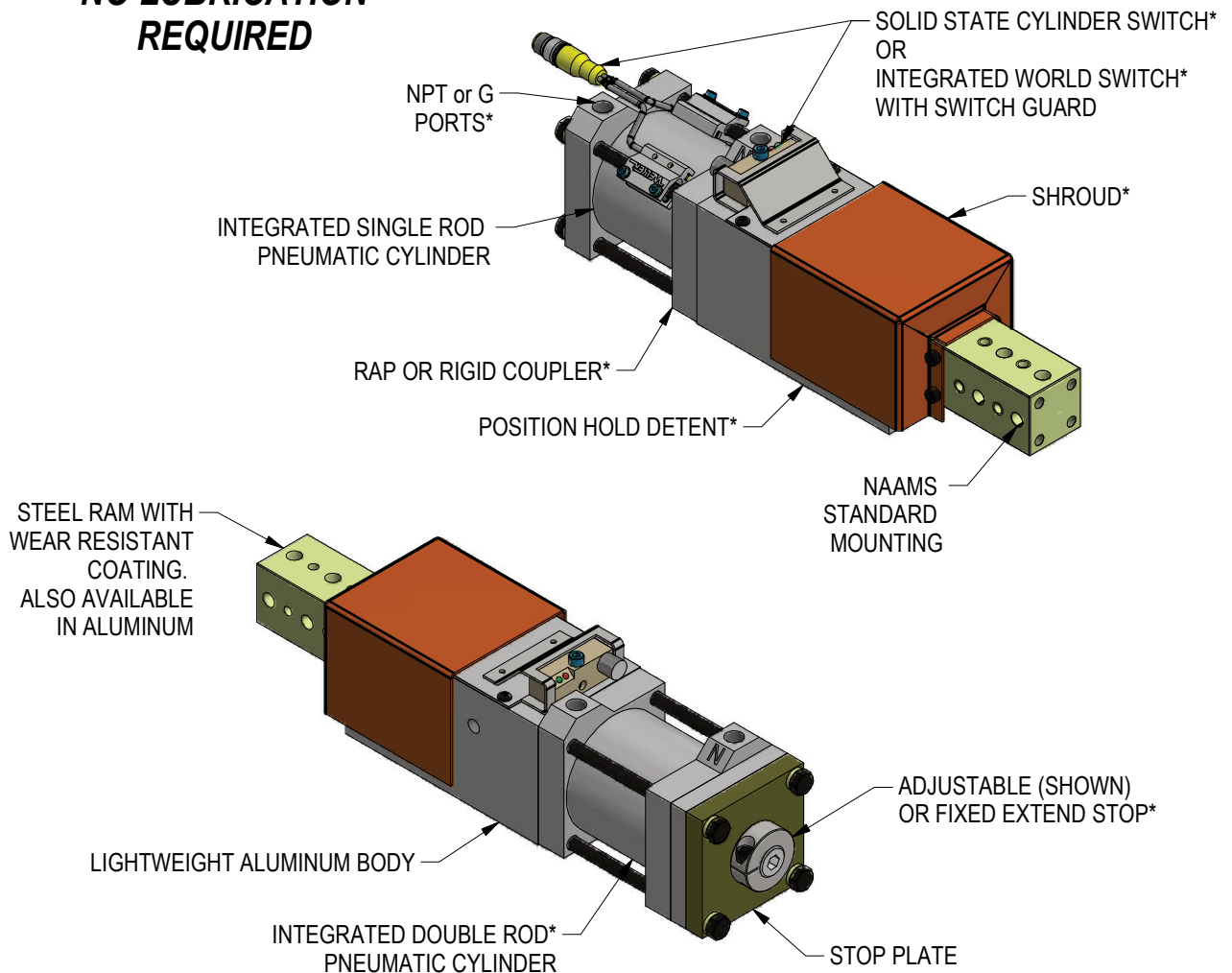

\*OPTIONAL

RELEASED 1/21/21

# ORDERING INFORMATION

NOTE: ALL BOXES MUST BE FILLED IN FOR A COMPLETE PART NUMBER

U	B	4												0		0
---	---	---	--	--	--	--	--	--	--	--	--	--	--	---	--	---

**Material**

- N Aluminum body, steel ram
- A Aluminum body & ram  
*Not available w Rap Coupler*

**Stroke**

- 025 025, 050, & 075mm Stroke

**Coupler**

- A Rap (shortens nominal cylinder stroke by 2mm)  
Rap only available with Actuator Options 01 or 02
- B Rigid

**Actuator**

- 01 Pneumatic - Single Rod - NPT
  - 02 Pneumatic - Single Rod - G Port
  - 03 Pneumatic - Double Rod - NPT Port\*
  - 04 Pneumatic - Double Rod - G Port\*
- \* Requires Extend Stop E, F, G, P, S or T

**Options**

- 0 None
- E Adjustable Extend Stop\* *Not available with Detent option*
- F Adjustable Extend Stop - 10mm Extra Stop\*  
*Not available with Detent option*
- G Fixed Extend Stop\*
- M Loose body for manual operation - **Requires Actuator 01 or 02**
- P Loose body for manual operation with Palm Button\*
- S Loose body for manual operation with Extend Stop ("E")\*  
*Not available with Detent option*
- T Loose body for manual operation with Fixed Extend Stop ("G")\*  
\*Requires Actuator option 03 or 04

**NOTE: Options E, F, G, S & T will shorten stroke - see Sht 3**

**Detent Option**

- 0 None
- D Detent  
(Steel ram only)  
*Not available with Adjustable Extend Stop options E, F, S*

**Port Position**

- A P1 Port Position
- B P2 Port Position
- C P3 Port Position
- D P4 Port Position

**Shroud**

- 0 No Shroud
- 1 Shroud

**Switch**

See Sheet 4

**Ram Style**

- D 4 Hole - Large
- L 4 Hole - Medium

**Manual Operation Note**

**Options M, P, S, T:**  
Loose body units are not held to industry standard tolerances

**Standard Options - All other options may affect price and delivery.**

(DO NOT SCALE DRAWING)



ENGINEERED PRODUCTS

(800) 229-0890 www.welkerproducts.com

# GENERAL DIMENSIONS

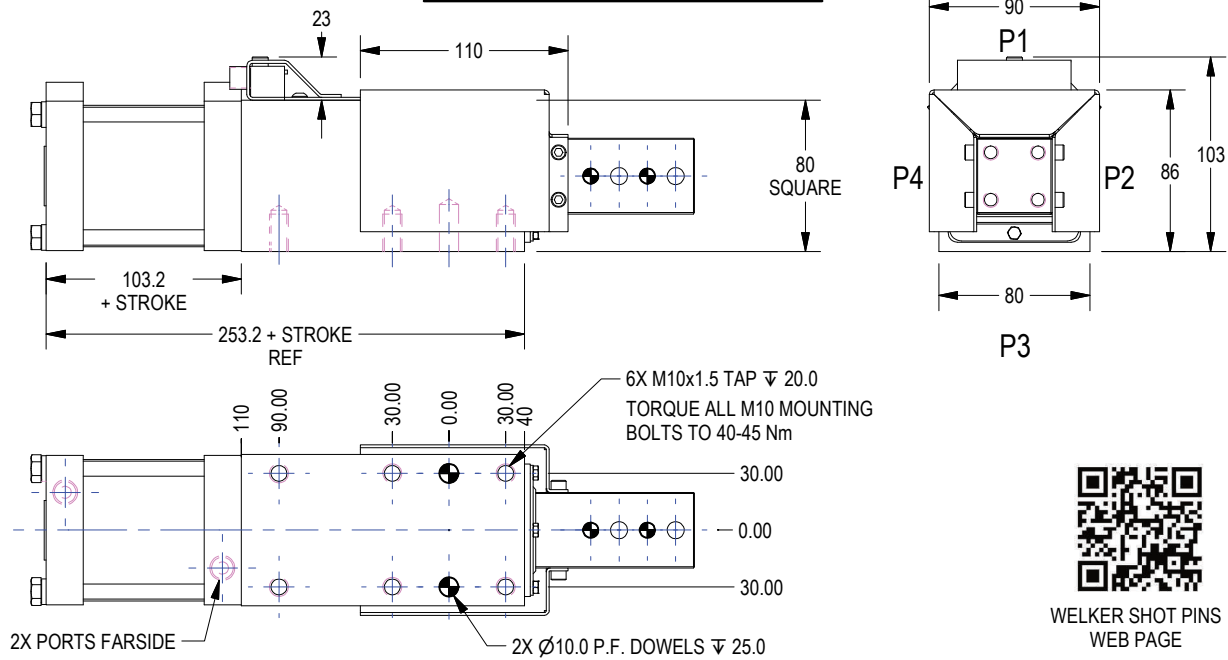

WELKER SHOT PINS  
WEB PAGE

## DOUBLE ROD CYLINDER WITH EXTEND STOP OPTION "E"

NOT AVAILABLE WITH  
DETENT OPTION

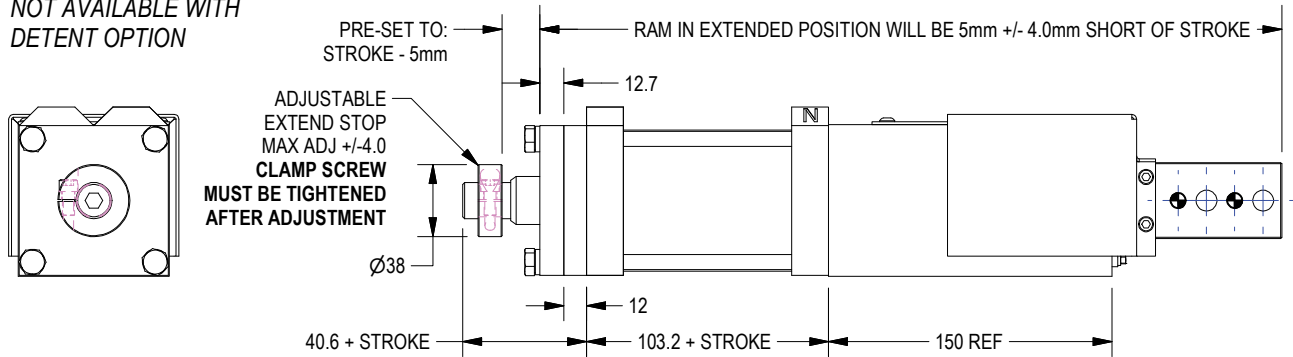

## DOUBLE ROD CYLINDER WITH EXTEND STOP OPTION "G"

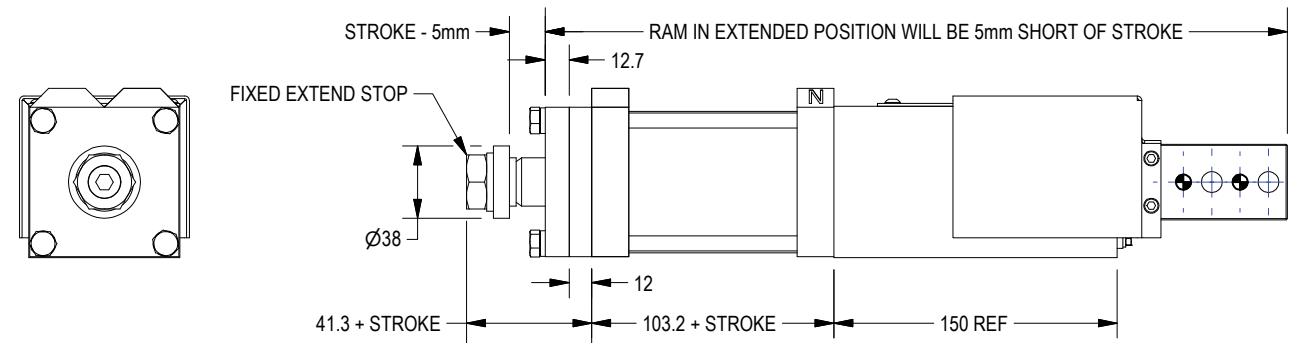

NOMINAL RAM	PNEUMATIC BORE	PORTS	PUSH Sq.In.	PULL Sq.In.
40	70	1/4" NPT OR G1/4	5.97	3.49

RECOMMENDED OPERATING PRESSURE:  
60-80 PSI, FLOW CONTROLS NOT REQUIRED



UNIT WEIGHTS (WEIGHTS SHOWN VARY WITH OPTIONS)				
ACTUATOR	RAM	25mm STROKE	50mm STROKE	75mm STROKE
01/02	STEEL	18 lbs	18.5 lbs	19.1 lbs
01/02	ALUMINUM	13 lbs	13.5 lbs	14 lbs
03/04	STEEL	19.4 lbs	20 lbs	25.2 lbs
03/04	ALUMINUM	14.5 lbs	15 lbs	21 lbs

SHEET 3

(DO NOT SCALE DRAWING)

**WELKER**

ENGINEERED PRODUCTS

(800) 229-0890 www.welkerproducts.com

# DOUBLE ROD CYLINDER WITH PALM BUTTON OPTION "P"

LOOSE BODY FOR MANUAL OPERATION

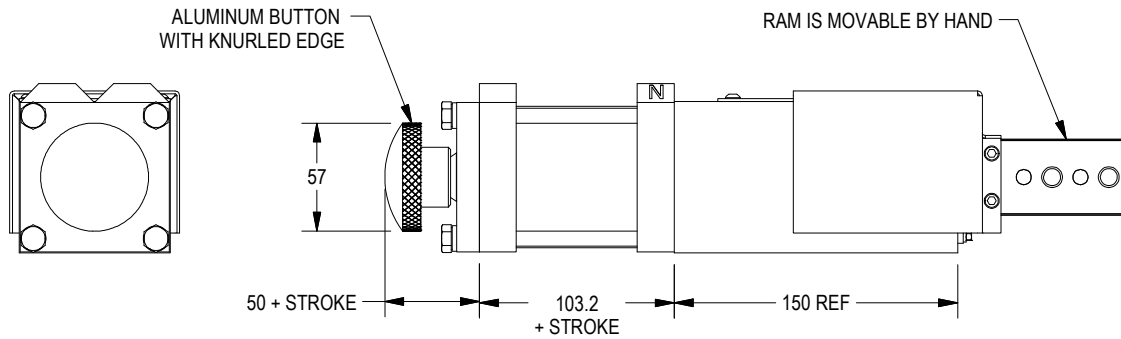

**Manual Operation Note:**

Loose body units are not held to industry standard tolerances

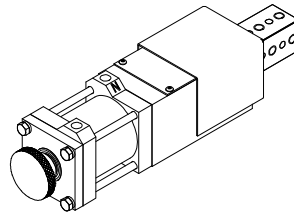

## SWITCH OPTIONS

	Order Number			Description
	SO1 EXTEND / SO1 RETRACT	Manufacturer's Part Number	Mfr.	ALL SWITCHES ARE QUICK DISCONNECT
WORLD SWITCHES INCLUDES SWITCH GUARD	00	NONE		
	99	WORLD SWITCH READY		Customer supplied World Switch
	AE / AR	Ni2-Q6.5-AP6-0.1-FS 4.4X3/S304	Turck	4-Wire, 4-Pin, DC M12 X 1 (PNP)
	BE / BR	Ni2-Q6.5-ADZ32-0.1-FSB 5.4X4/S304	Turck	4-Wire, 5-Pin, AC/DC 1/2-20 (N.O.)
	CE / CR	Ni2-Q6.5-AN6-0.1-FS 4.4X3/S304	Turck	4-Wire, 4-Pin, DC M12 X 1 (NPN)
	DE / DR	NBN2-F581-100S6-E8-V1	Pepperl & Fuchs	4-Wire, 4-Pin, DC M12 X 1 (PNP)
	EE / ER	BES-Z02KR2-PSC20F-P100-S04-V	Balluff	3-Wire, 4-Pin, DC M12 X 1 (PNP)
	JE / JR	IN5374	Efactor	3-Wire, 4-Pin, DC M12 X 1 (PNP)
	ZE / ZR	WWS001A	Welker	4-Wire, 4-Pin, DC M12 X 1 (PNP)
CYLINDER SWITCHES	L3	SWITCH L3 ~ Weld field immune*, comparable to World Switches. Dual sensor, single connector switch	Welker	4-Wire, 4-Pin, DC (PNP) M12 X 1
	L5	MK5113 ~ Single sensor, single connector switch: 2 switches installed on cylinder	ifm Efactor	3-Wire, 4-Pin, DC (NPN) M12 X 1

**Standard Options - All other options may affect price and delivery.**

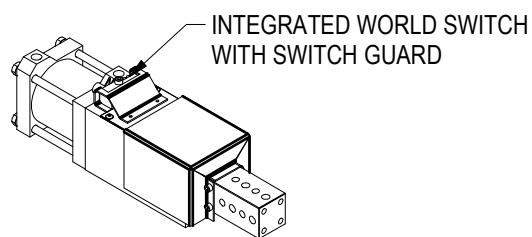
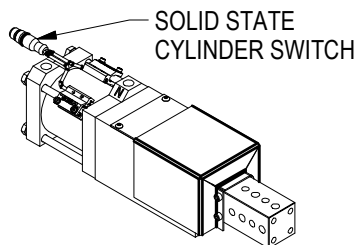

\*Note that some mid and low frequency DC resistance applications (i.e. aluminum resistance welding applications) may cause a fault. In these applications, it is recommended that the sensor be ignored/bypassed during the welding cycle.

(DO NOT SCALE DRAWING)



ENGINEERED PRODUCTS

(800) 229-0890 www.welkerproducts.com

# STANDARD RAM OPTIONS

(SEE SUPPLEMENTAL RAM SHEET FOR NON-STANDARD RAM OPTIONS)

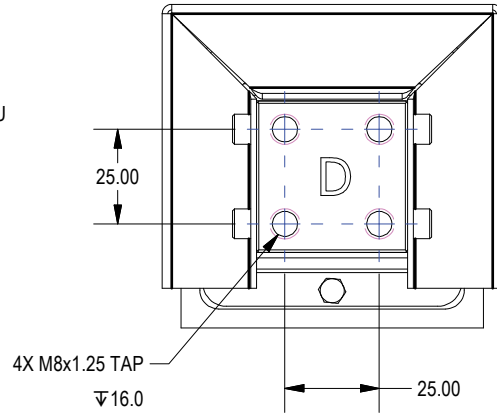
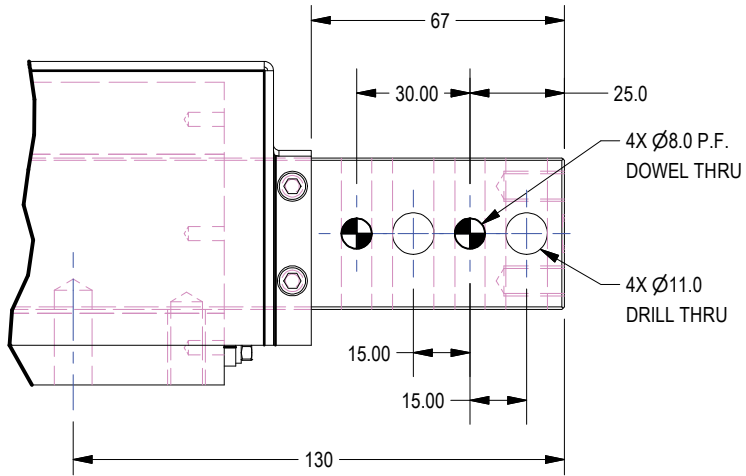

RAM STYLE 'D'

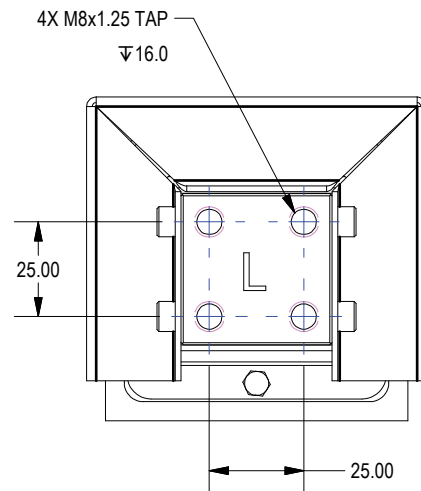
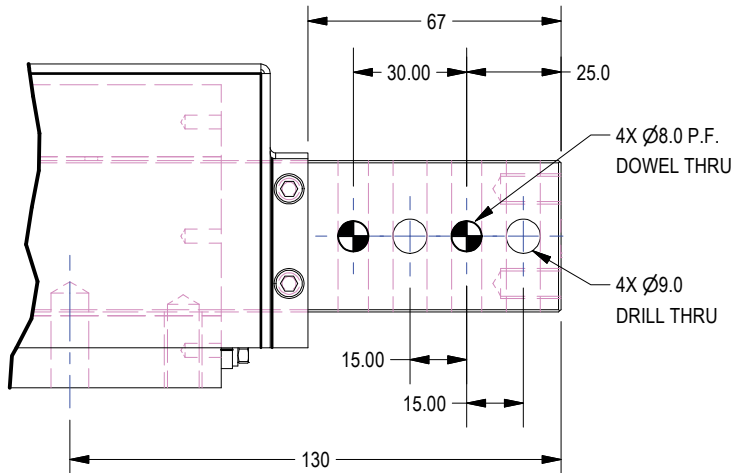

RAM STYLE 'L'

(DO NOT SCALE DRAWING)



ENGINEERED PRODUCTS

(800) 229-0890 [www.welkerproducts.com](http://www.welkerproducts.com)

## DETENT OPTION

U
B
4
N
0
2
5
B
0
1
0
D
A
E
1
A
0
0
0

**Detent**  
(Steel ram only)

0 None

D Detent

**NOT AVAILABLE WITH ADJUSTABLE STOP OPTIONS E, F, S**

DETENT OPTION IS A BALL SPRING PLUNGER INSTALLED IN UNIT BODY TO ASSIST WITH HOLDING THE RAM IN EXTENDED POSITION (ONLY) WITH LOSS OF AIR PRESSURE.

DETENT IS NOT DESIGNED TO HOLD GEO LOCATION WITH LOSS OF AIR PRESSURE.

DETENT OPTION WILL CAUSE VISIBLE LINES IN THE RAM'S EXTERIOR COATING.

**BALL SPRING PLUNGER IS A WEAR ITEM AND WILL NEED TO BE REPLACED AT RECOMMENDED INTERVALS.**

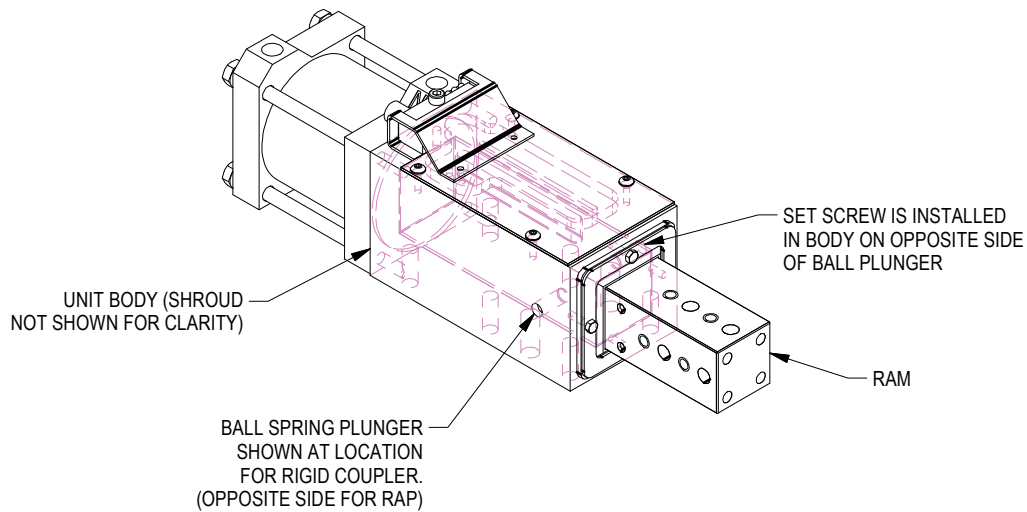

**NOTE: IF RAP/RIGID COUPLER IS SWITCHED IN THE FIELD, THE BALL PLUNGER AND SET SCREW MUST BE SWITCHED TO OPPOSITE SIDES.**

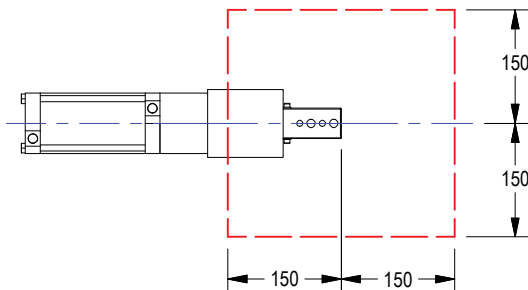

DETENT OPTION EFFECTIVE WEIGHT LIMIT IS 24 LBF FOR VERTICAL APPLICATIONS.

MOUNTED TOOLING MUST BE WITHIN APPROVED APPLICATION RADIUS FROM END OF RAM.

(DO NOT SCALE DRAWING)

**WELKER**

ENGINEERED PRODUCTS

(800) 229-0890 www.welkerproducts.com

## Welker UB4 Series Shot Pin Technical Information

**Body Mounting:** Square ram packages are high precision full contact plane bearing units and therefore must be mounted to a flat surface. **Mounting surfaces must be flat within .002" (0.05mm).** Tighten M10 mounting screws to 45 Nm (33 ft-lb).

**Ram Mounting:** Square ram shot pin units use a standard NAAMS L-Block pattern with 15mm spacing. Spacing allows mounting of 3 and 4 hole pin retainers and L-blocks to the ram. Through holes can be tapped and fitted with standard thread inserts.

**Shrouds:** Safety orange steel shrouds are available for additional protection. Shrouds prevent undesirable buildup of contamination from welding and machining applications. Welker specifically recommends shroud usage in MIG, TIG and arc welding applications. Shrouds should only be removed if clearance problems exist and conditions permit. Consult Welker.

**Wipers:** The wiper is the only maintenance item on Welker pin units. It is a custom molded moly impregnated urethane wiper. Welker recommends changing the wiper yearly. Specific applications may require more or less frequent wiper service.

**Stroke:** The stroke accuracy of shot pins is limited to that of the cylinder. Normal cylinder stroke accuracy is  $\pm .015"$  (0.38mm). For adjustable and repeatable "end of stroke" conditions, see extend stop options. Rap couplings cause the unit to be less than the nominal stroke of the cylinder. The 40mm ram units have a 2mm rap. The rap allows the cylinder to accelerate without load, acting like a slide hammer. The impact of the coupler helps free tooling from a bound condition, similar to a dowel puller. Most applications using a pneumatic shot pin should have rap couplings while most hydraulic shot pin applications should use a rigid coupler. Rigid couplers must be used on all extend and retract stop units.

Welker cylinders do not require lubrication.

**Switch:** UB4 is available with World Switch or cylinder switch.

**Repeatability:** Shot pin units utilize a full contact bearing surface for high repeatability. Repeatability within  $\pm .002"$  (0.05mm) part to part is achievable.

**Wear:** Defined as variance in position under load over time. Shot pin tests indicate maximum wear of  $.002"$  wear at 3 million cycles.

**Loading and Deflection:** Maximum deflection is  $\pm .005"$  and is measured at the **end of the ram** up to the specified strokes and up to the loads and distances as shown below. Longer extensions can be used at lower tolerances and loads. Pins mounted closer to the body exhibit less deflection. For applications with longer strokes and higher loads, consult Welker.

