

LST SERIES PART POSITIONER

**ONE ACTUATOR TO EXTEND AND TIP TOOLING AWAY
REPEATABLE RETRACTED POSITION**

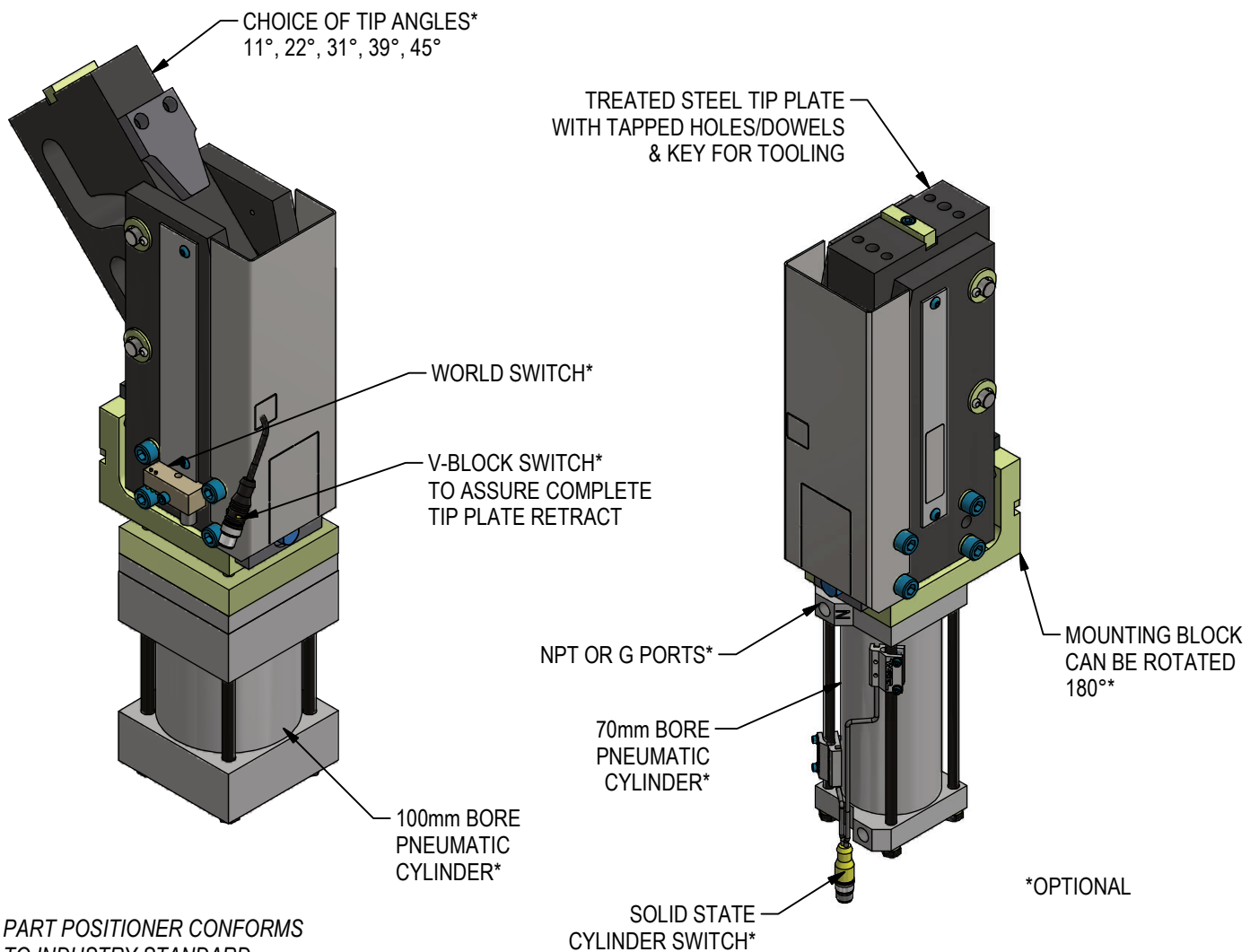

*PART POSITIONER CONFORMS
TO INDUSTRY STANDARD
REPEATABILITY TOLERANCES
FOR GEOMETRY STATIONS*

MINIMUM 2-SECOND CYCLE TIME FOR ONE DIRECTION

RELEASED 1/20/21

ORDERING INFORMATION

NOTE: ALL BOXES MUST BE FILLED IN FOR A COMPLETE PART NUMBER

L	S	T			A										0
---	---	---	--	--	---	--	--	--	--	--	--	--	--	--	---

Angle (See Sheet 4) _____
045 11°, 22°, 31°, 39°, or 45°

Actuator (See Sheet 5) _____
01 Welker 70mm Bore w/ NPT Ports
02 Welker 70mm Bore w/ G Ports
05 Welker 100mm Bore w/ NPT Ports
06 Welker 100mm Bore w/ G Ports

Shroud (See Sheet 6) _____
0 Base Shroud
1 Tip Plate Shroud

Mount (See Sheet 7) _____
A Mounting Base as Shown
B Mounting Base Rotated 180 degrees

Switch Options (See Sheets 8, 9) _____

Switch Position (See Sheets 8, 9) _____
1 Switch @ Position 1
2 Switch @ Position 2
3 Switch @ Position 3
4 Switch @ Position 4

*World Switch only available with
Switch Position 2*

Port Position (See Sheet 5) _____
A Port @ Position 1
B Port @ Position 2
C Port @ Position 3
D Port @ Position 4

V-Block Switch (See Sheet 10) _____
0 No V-Block Switch
S V-Block Switch

Side Load Bearings (See Sheet 13) _____
0 None
B Side Load Bearing Plates



UNIT WEIGHTS**	
UNIT	WEIGHT (LBS)**
70mm BORE CYLINDER	53
100mm BORE CYLINDER	64

**WEIGHTS SHOWN ARE APPROXIMATE AND WILL VARY WITH OPTION SELECTION.

MINIMUM 2-SECOND CYCLE TIME FOR ONE DIRECTION

(DO NOT SCALE DRAWING)

ENGINEERED PRODUCTS

(800) 229-0890 www.welkerproducts.com

DIMENSIONS

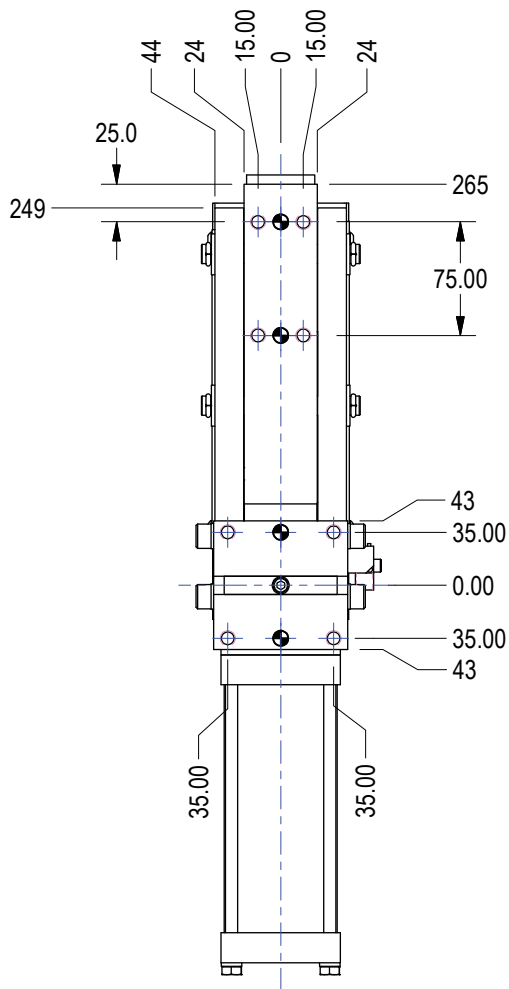
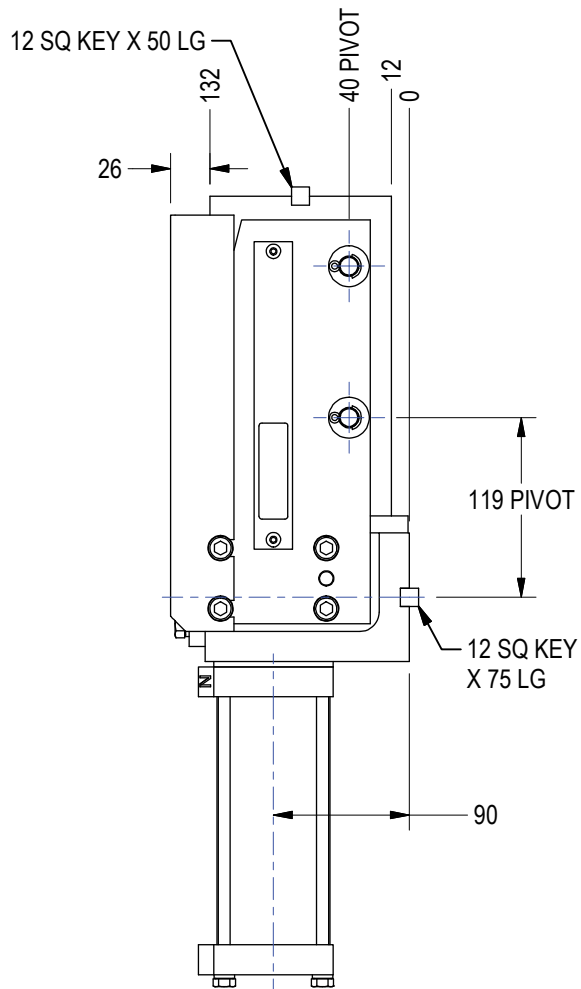
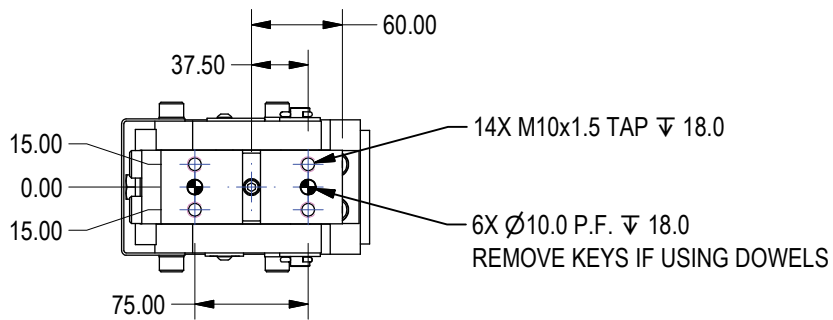

UNIT SHOWN RETRACTED



WELKER PART POSITIONER
WEB PAGE

(DO NOT SCALE DRAWING)

MINIMUM 2-SECOND CYCLE TIME FOR ONE DIRECTION

TIP ANGLE INFORMATION

L S T 0 4 5 A 0 1 0 A L 3 1 A 0 0 0

Angle
LST 11, 22, 31, 39 & 45

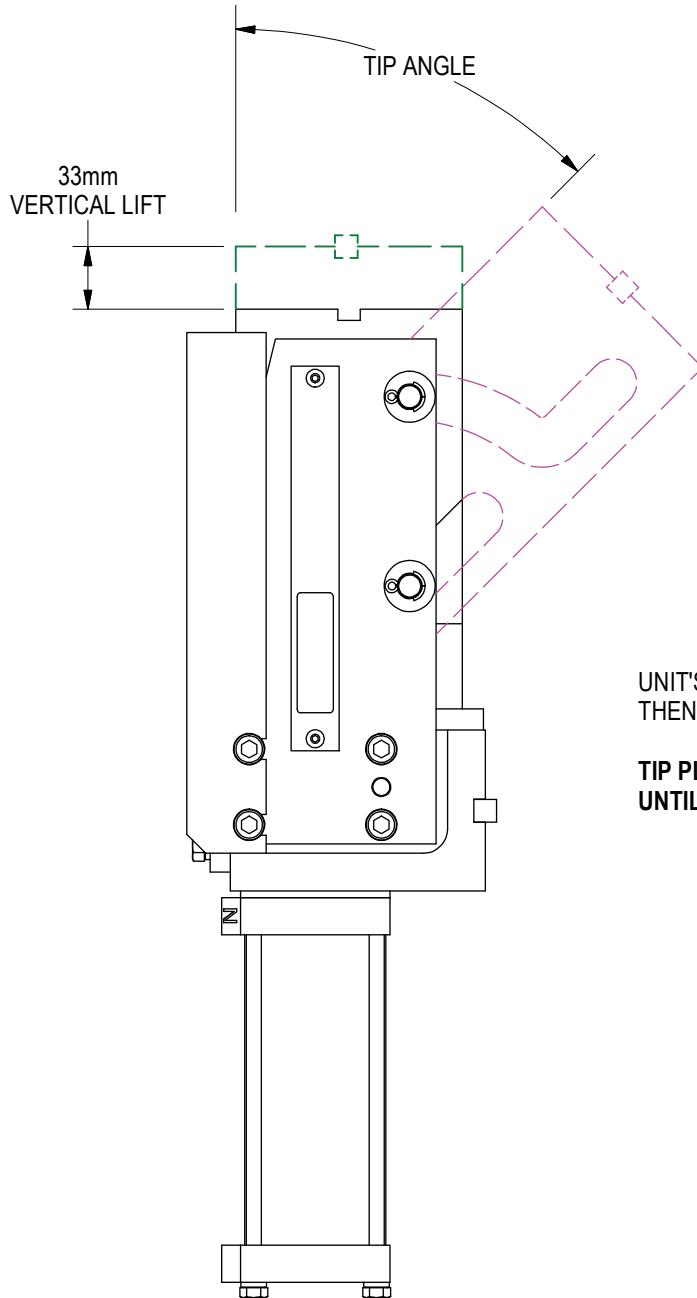

UNIT'S TIP PLATE TRAVELS VERTICALLY THEN TIPS OUT TO SELECTED ANGLE.

TIP PLATE CONTINUES TO TRAVERSE UNTIL CYLINDER STROKE IS COMPLETE.

MINIMUM 2-SECOND CYCLE TIME FOR ONE DIRECTION

(DO NOT SCALE DRAWING)

WELKER
ENGINEERED PRODUCTS
(800) 229-0890 www.welkerproducts.com

ACTUATOR INFORMATION

L
S
T
0
4
5
A
0
1
0
A
L
3
1
A
0
0
0

Actuator

- 01 Welker 70mm Bore w/ NPT Ports
- 02 Welker 70mm Bore w/ G Ports
- 05 Welker 100mm Bore w/ NPT Ports
- 06 Welker 100mm Bore w/ G Ports

Port Position

- A Port @ P1
- B Port @ P2
- C Port @ P3
- D Port @ P4

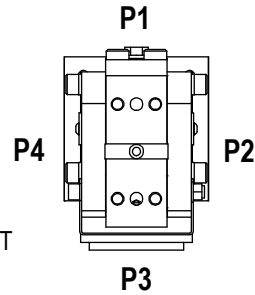

**ACTUATOR OPTIONS
01 - 02**

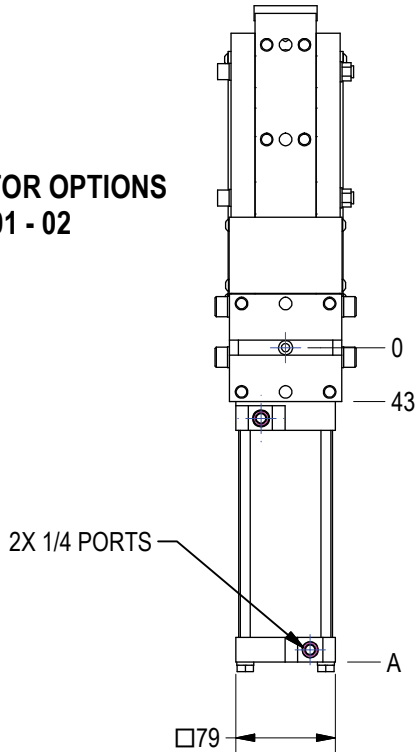

**ACTUATOR OPTIONS
05 - 06**

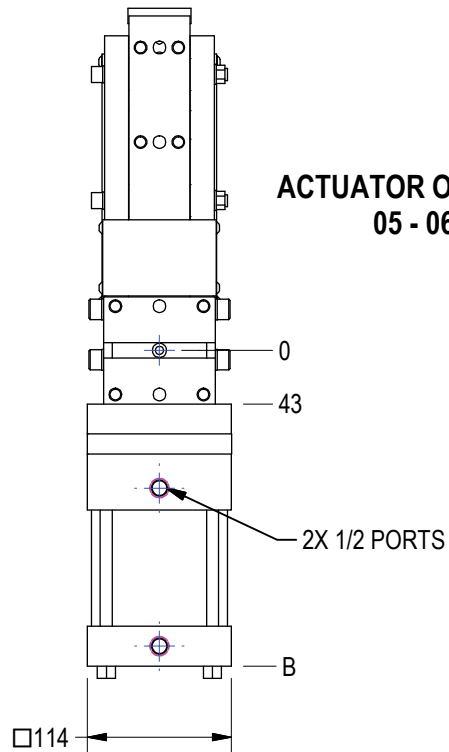

TIP ANGLE	A	B	CYLINDER STROKE
11°	250	252	60
22°	250	262	70
31°	250	272	80
39°	250	282	90
45°	250	292	100

NOTE: DIMENSIONS SHOWN ARE mm

MINIMUM 2-SECOND CYCLE TIME FOR ONE DIRECTION

(DO NOT SCALE DRAWING)

WELKER
ENGINEERED PRODUCTS
(800) 229-0890 www.welkerproducts.com

SHROUD INFORMATION

L
S
T
0
4
5
A
0
1
0
A
L
3
1
A
0
0
0

Shroud

- 0** Base Shroud
- 1** Tip Plate Shroud
(Recommended for heavily contaminated environments such as MIG and arc welding)

TIP PLATE SHROUD OPTION "1"

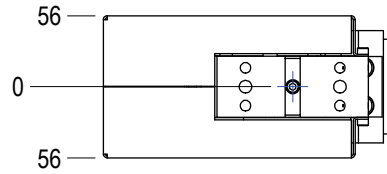
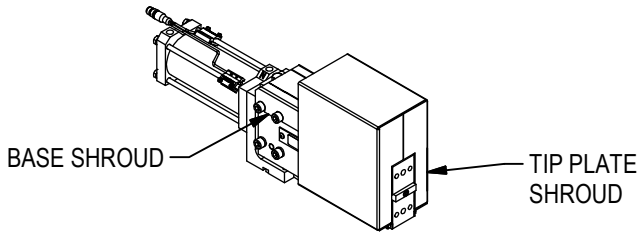

BASE SHROUD OPTION "0"

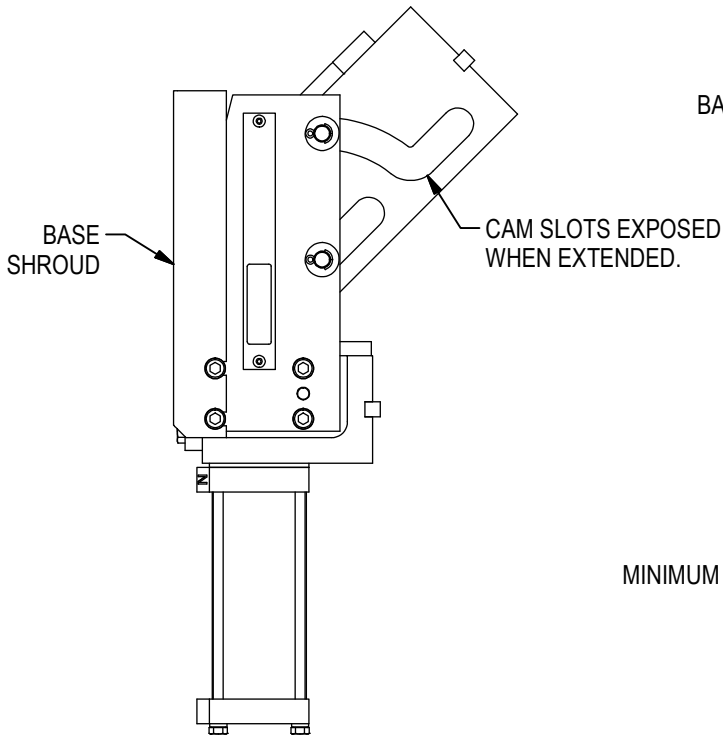

TIP PLATE SHROUD

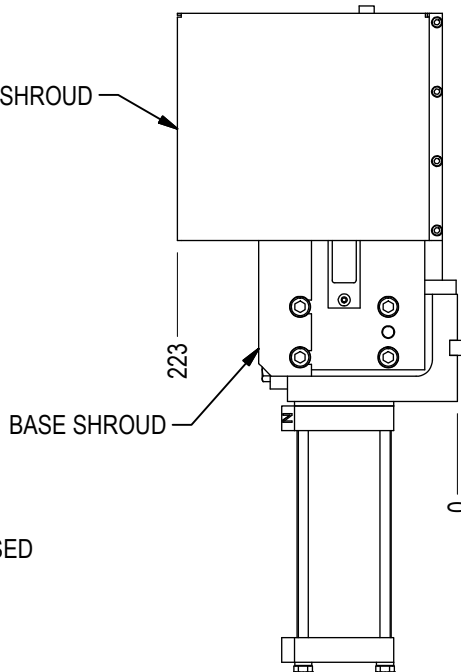

MINIMUM 2-SECOND CYCLE TIME FOR ONE DIRECTION

(DO NOT SCALE DRAWING)

ENGINEERED PRODUCTS

(800) 229-0890 www.welkerproducts.com

MOUNT INFORMATION

L S T 0 4 5 A 0 1 0 A L 3 1 A 0 0 0

Mount

- A Base Mount @ 0
- B Base Mount @ 180

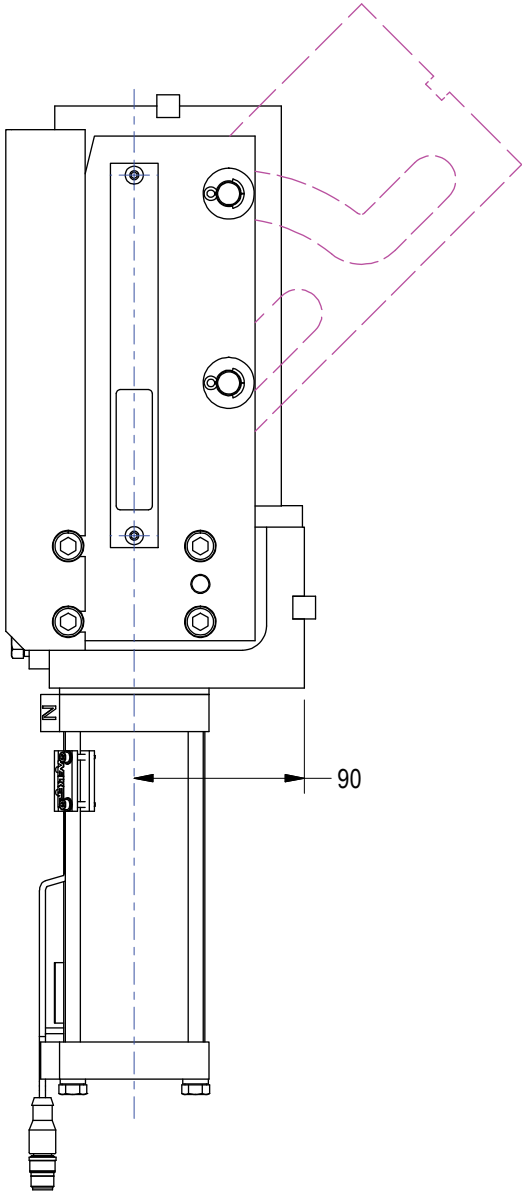

MOUNT "A"

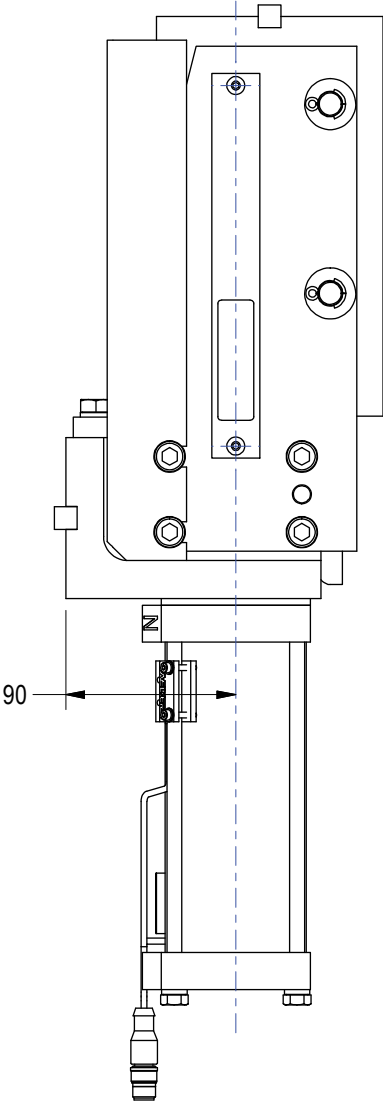

MOUNT "B"

MINIMUM 2-SECOND CYCLE TIME FOR ONE DIRECTION

(DO NOT SCALE DRAWING)



ENGINEERED PRODUCTS
(800) 229-0890 www.welkerproducts.com

WORLD SWITCH INFORMATION

L
S
T
0
4
5
A
0
1
0
A
Z
E
2
A
0
0
0

Switch Options _____

- L3** Solid State Cylinder Switch (See sheet 9)
- ZE** World Switch (see chart below)

Switch Position _____

- 2** Switch @ Position 2

WORLD SWITCH CHART

	Order Number SO1 EXTEND / SO1 RETRACT	Part Number	Manufacturer	Description
LST World Switches	SE / SR	Ni2-Q6.5-AP6-0.16-FS 4.4X3/S304	Turck	4-Wire, 4-Pin, DC M12 X 1 (PNP)
	TE / TR	Ni2-Q6.5-ADZ32-0.16-FSB 5.4X4/S304	Turck	4-Wire, 5-Pin, AC/DC 1/2-20 (N.O.)
	UE / UR	Ni2-Q6.5-AN6-0.16-FS 4.4X3/S304	Turck	3-Wire, 4-Pin, DC M12 X 1 (NPN)
	VE / VR	NBN2-F581-160S6-E8-V1	Pepperl & Fuchs	4-Wire, 4-Pin, DC M12 X 1 (PNP)
	WE / WR	BES-Z02KR2-PSC20F-P165-S04-V	Balluff	3-Wire, 4-Pin, DC M12 X 1 (PNP)
	YE / YR	IN5375	Efector	3-Wire, 4-Pin, DC M12 X 1 (PNP)
	ZE / ZR	WWS001A	Welker	4-Wire, 4-Pin, DC M12 X 1 (PNP)

Standard Switch Option - All other options may affect price and delivery

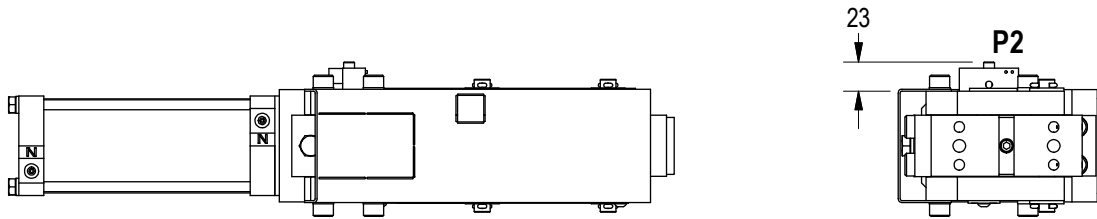

VIEW SHOWN WITH WORLD SWITCH
WORLD SWITCHES ARE AVAILABLE **ONLY** WITH SWITCH POSITION 2.

MINIMUM 2-SECOND CYCLE TIME FOR ONE DIRECTION

(DO NOT SCALE DRAWING)

ENGINEERED PRODUCTS

(800) 229-0890 www.welkerproducts.com

CYLINDER SWITCH INFORMATION

L
S
T
0
4
5
A
0
1
0
A
L
3
1
A
0
0
0

Switch Options

- L3** Solid State Cylinder Switch (see chart below)
- AE** World Switch (see sheet 8)

Switch Position

- 1** Switch @ Position 1
- 2** Switch @ Position 2
- 3** Switch @ Position 3
- 4** Switch @ Position 4

Switch	Part Number	Manufacturer	Description
Cylinder Switches	L3	SWITCH L3*	L3 sw itch is w eld field immune, comparable to World Sw itches. Dual sensor sw itch, 1 per cylinder
	L5	MK5113	Single sensor sw itch, 2 sw itches per cylinder

Standard Switch Option - All other options may affect price and delivery

*Note that some mid and low frequency DC resistance applications (i.e. aluminum resistance welding applications) may cause a fault. In these applications, it is recommended that the sensor be ignored/bypassed during the welding cycle.

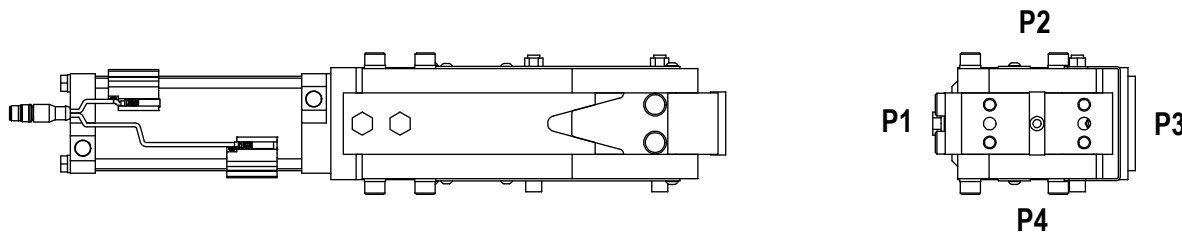

VIEW SHOWN WITH SOLID STATE CYLINDER SWITCH IN POSITION 1

MINIMUM 2-SECOND CYCLE TIME FOR ONE DIRECTION

(DO NOT SCALE DRAWING)

ENGINEERED PRODUCTS

(800) 229-0890 www.welkerproducts.com

V-BLOCK SWITCH INFORMATION

L
S
T
0
4
5
A
0
1
0
A
L
3
1
A
0
0
0

Mount

- A** Base Mount @ 0
- B** Base Mount @ 180

V-Block Switch Options

- 0** No V-Block Switch
- S** V-Block Switch

**V-BLOCK SWITCH
MOUNT "A"**

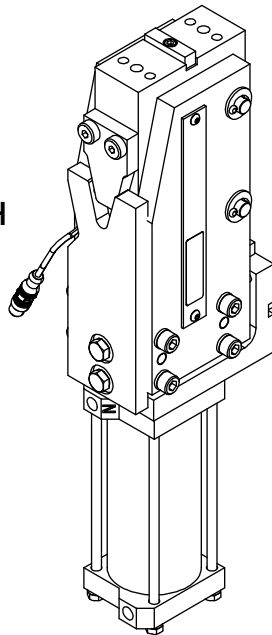

*SHROUD NOT SHOWN
FOR CLARITY*

**V-BLOCK SWITCH
MOUNT "B"**

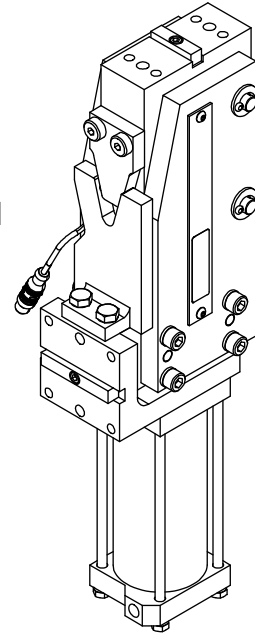

V-BLOCK SWITCH FEATURES:

4 LEDs: (2) GREEN, POWER ON, (2) YELLOW, OUTPUT

ANTI-VIBRATION DETENT

EUROFAST M12X1 MALE 4 PIN

Ø4.22mm FIREFAST 300mm TOTAL LENGTH INCLUDING CONNECTOR

FOR DETAILED SWITCH SPECIFICATIONS SEE WELKER SMART STOP CATALOG

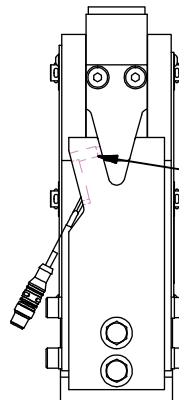

SWITCH IS EMBEDDED IN LOWER WEDGE PLATE TO ENSURE COMPLETE TIP PLATE RETRACT

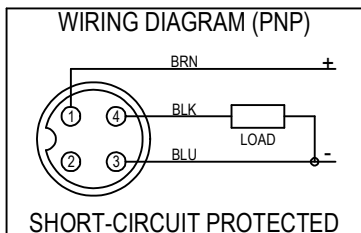

MINIMUM 2-SECOND CYCLE TIME FOR ONE DIRECTION

(DO NOT SCALE DRAWING)

ENGINEERED PRODUCTS

(800) 229-0890 www.welkerproducts.com

LST PART POSITIONER APPLICATION DATA: 70mm BORE CYLINDER

VERTICAL APPLICATIONS

NOTE: CENTER OF GRAVITY AND PART CONTACT TOOLING MUST BE WITHIN DESIGNATED ZONE

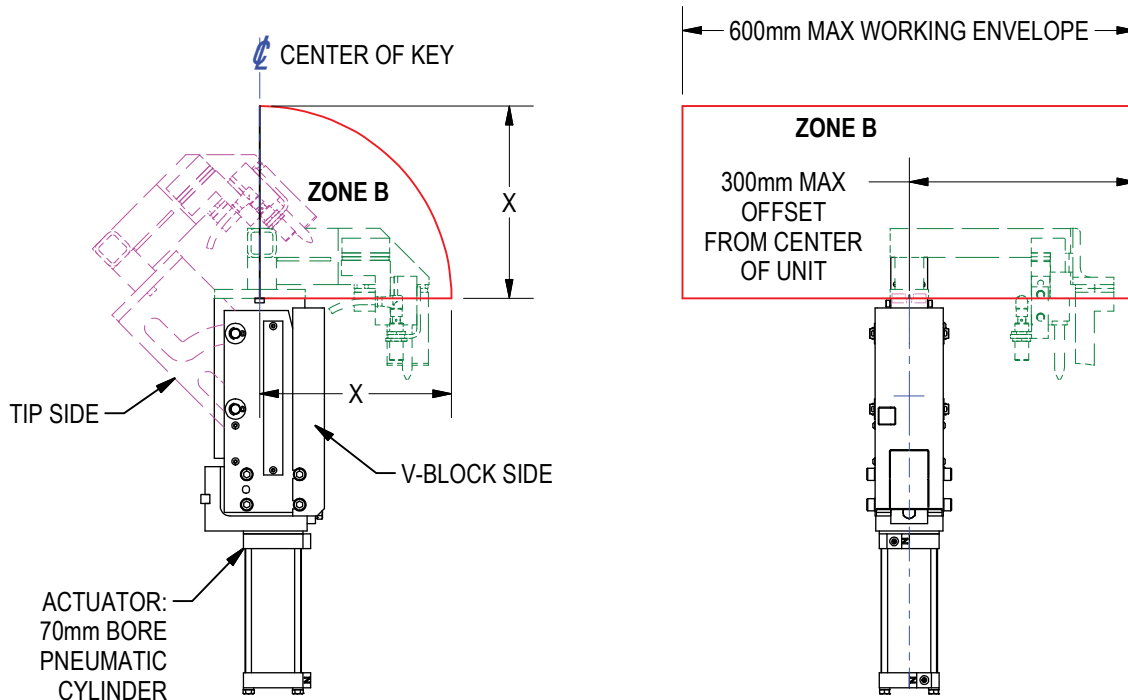

HORIZONTAL MOUNT, VERTICAL MOVEMENT APPLICATIONS

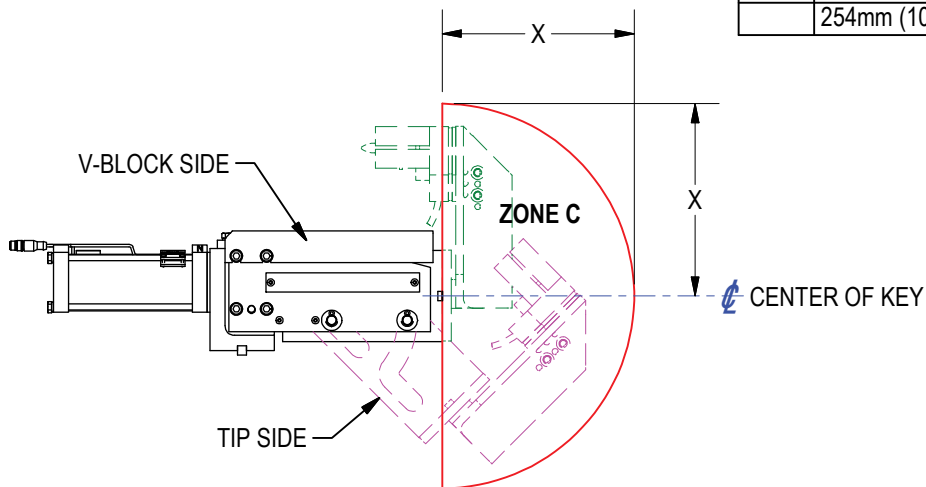

70mm BORE CYLINDER		
ZONE	DIM X	MAX LOAD
B	152mm (6")	70 LBS @ 60 PSI
	152mm (6")	70 LBS @ 80 PSI
	254mm (10") MAX	30 LBS @ 60 PSI
	254mm (10") MAX	40 LBS @ 80 PSI
C	254mm (10")	10 LBS @ 60 PSI
	254mm (10")	18 LBS @ 80 PSI

MINIMUM 2-SECOND CYCLE TIME FOR ONE DIRECTION

(DO NOT SCALE DRAWING)



ENGINEERED PRODUCTS

(800) 229-0890 www.welkerproducts.com

LST PART POSITIONER APPLICATION DATA: 100mm BORE CYLINDER

VERTICAL APPLICATIONS

NOTE: CENTER OF GRAVITY AND PART CONTACT TOOLING MUST BE WITHIN DESIGNATED ZONE

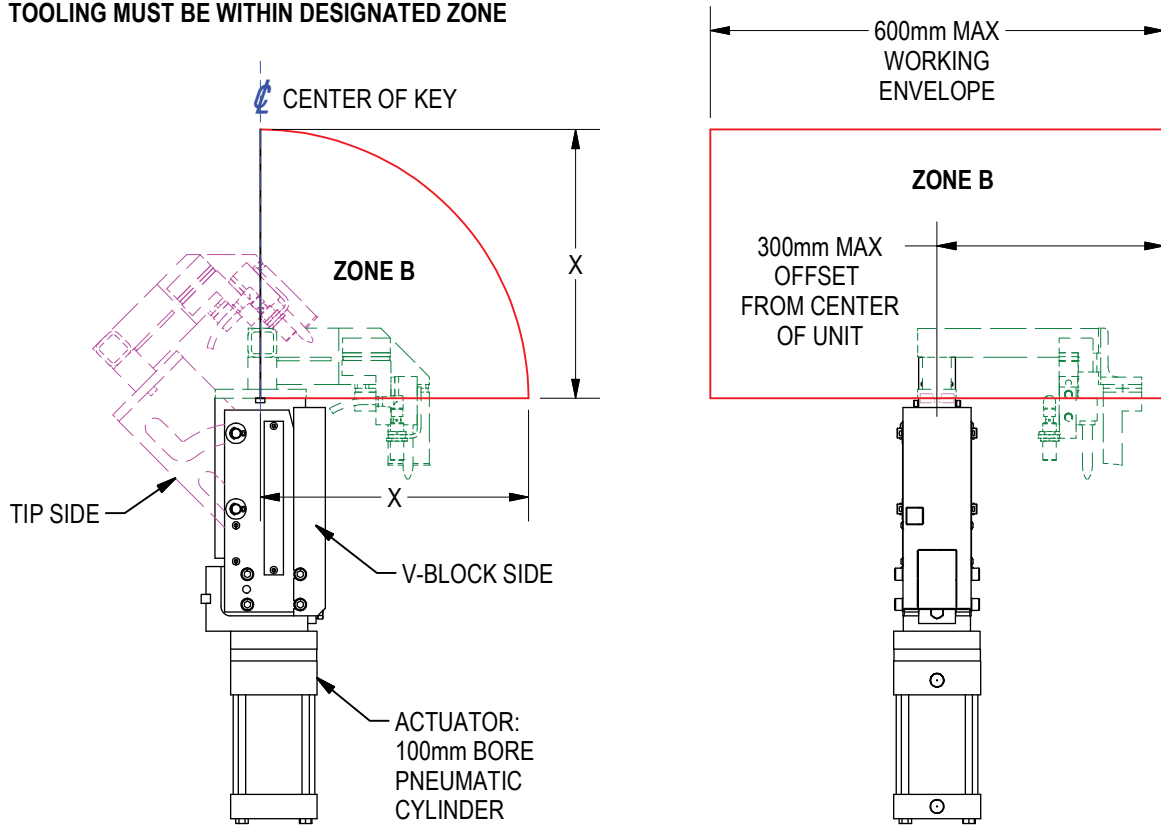

HORIZONTAL MOUNT, VERTICAL MOVEMENT APPLICATIONS

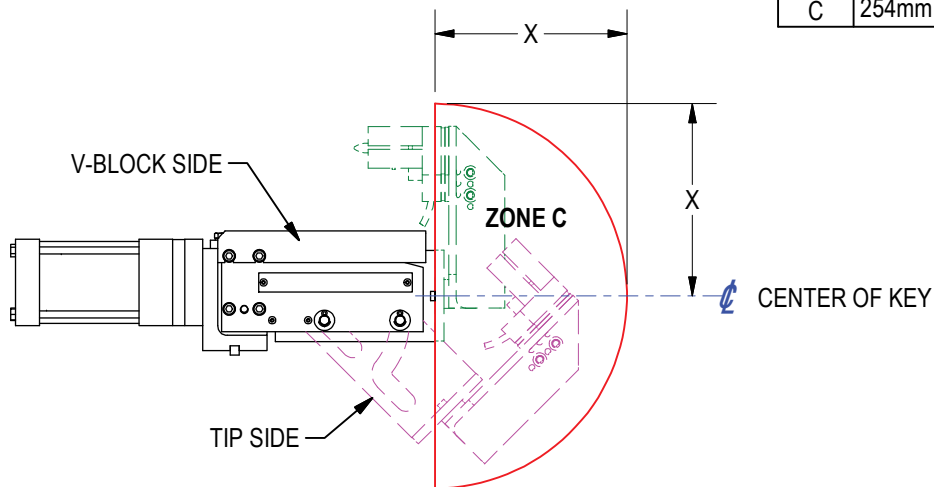

100mm BORE CYLINDER		
ZONE	DIM X	MAX LOAD
B	355mm (14") MAX	45 LBS @ 60 PSI
	355mm (14") MAX	60 LBS @ 80 PSI
C	254mm (10")	30 LBS

MINIMUM 2-SECOND CYCLE TIME FOR ONE DIRECTION

(DO NOT SCALE DRAWING)



ENGINEERED PRODUCTS

(800) 229-0890 www.welkerproducts.com

LST PART POSITIONER APPLICATION DATA: HORIZONTAL MOUNT, HORIZONTAL MOVEMENT

L S T 0 4 5 A 0 1 0 A L 3 1 A 0 **B** 0

LST units for horizontal mount, horizontal movement applications must be ordered with Side Load Bearing Plates

Side Load Bearings

- 0 None
- B Side Load Bearing Plates

NOTE: CENTER OF GRAVITY AND PART CONTACT TOOLING MUST BE WITHIN DESIGNATED ZONE

70mm BORE CYLINDER		
ZONE	DIM X	MAX LOAD
D	254mm (10")	20 LBS @ 60 PSI

100mm BORE CYLINDER		
ZONE	DIM X	MAX LOAD
D	355mm (14")	30 LBS @ 60 PSI

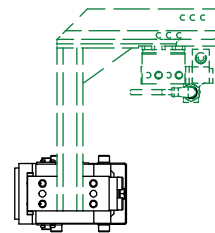
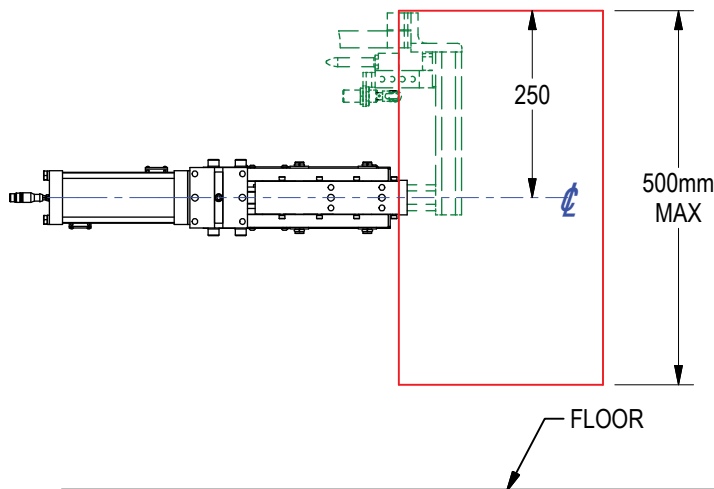
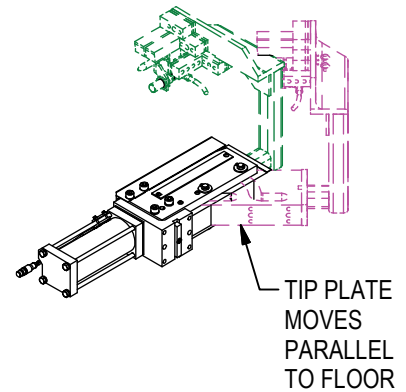
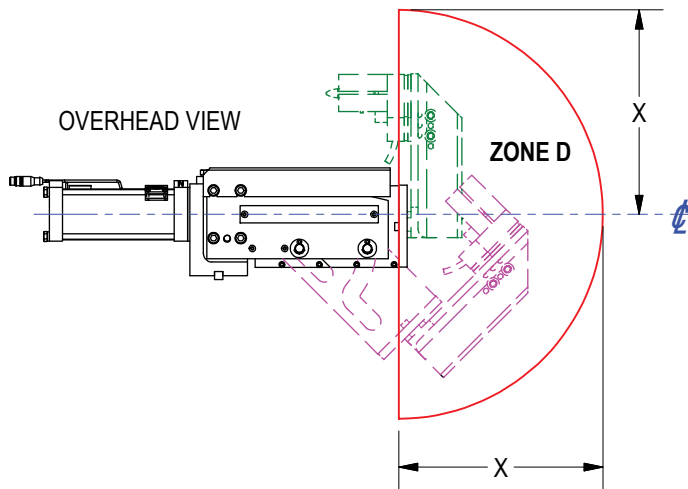

MINIMUM 2-SECOND CYCLE TIME FOR ONE DIRECTION

(DO NOT SCALE DRAWING)



ENGINEERED PRODUCTS

(800) 229-0890 www.welkerproducts.com

LST PART POSITIONER: REQUIRED CRITERIA FOR APPLICATION APPROVAL

APPLICATION DATA MUST BE SUBMITTED FOR WELKER APPROVAL WITH THE FOLLOWING CRITERIA FOR ALL PART POSITIONER APPLICATIONS. PLEASE ATTACH THIS WORKSHEET TO YOUR BUY OFF AND INCLUDE A MINIMUM OF TWO SCREEN SHOTS OF YOUR APPLICATION WITH UNIT TIP PLATE IN EXTENDED POSITION.

FLOW CONTROLS ARE REQUIRED FOR ALL APPLICATIONS.

REF	DESCRIPTION	VALUE
	WELKER UNIT PART NUMBER	
	WEIGHT/MASS OF LOAD (TOOLING PLUS PARTS)	lbf
C	DISTANCE FROM PIVOT POINT TO LOAD CENTER OF GRAVITY	mm
D	DISTANCE FROM PIVOT POINT TO LOAD CENTER OF GRAVITY	mm
E	DISTANCE FROM CENTER OF KEYWAY TO LOAD CENTER OF GRAVITY	mm
F	ORIENTATION OF UNIT TO FLOOR (0° = PARALLEL TO FLOOR)	°
	UNIT MOUNT	VERTICAL HORIZONTAL
	TIP PLATE MOVEMENT	VERTICAL HORIZONTAL

PLEASE SUBMIT VIEWS BELOW FOR APPROVAL

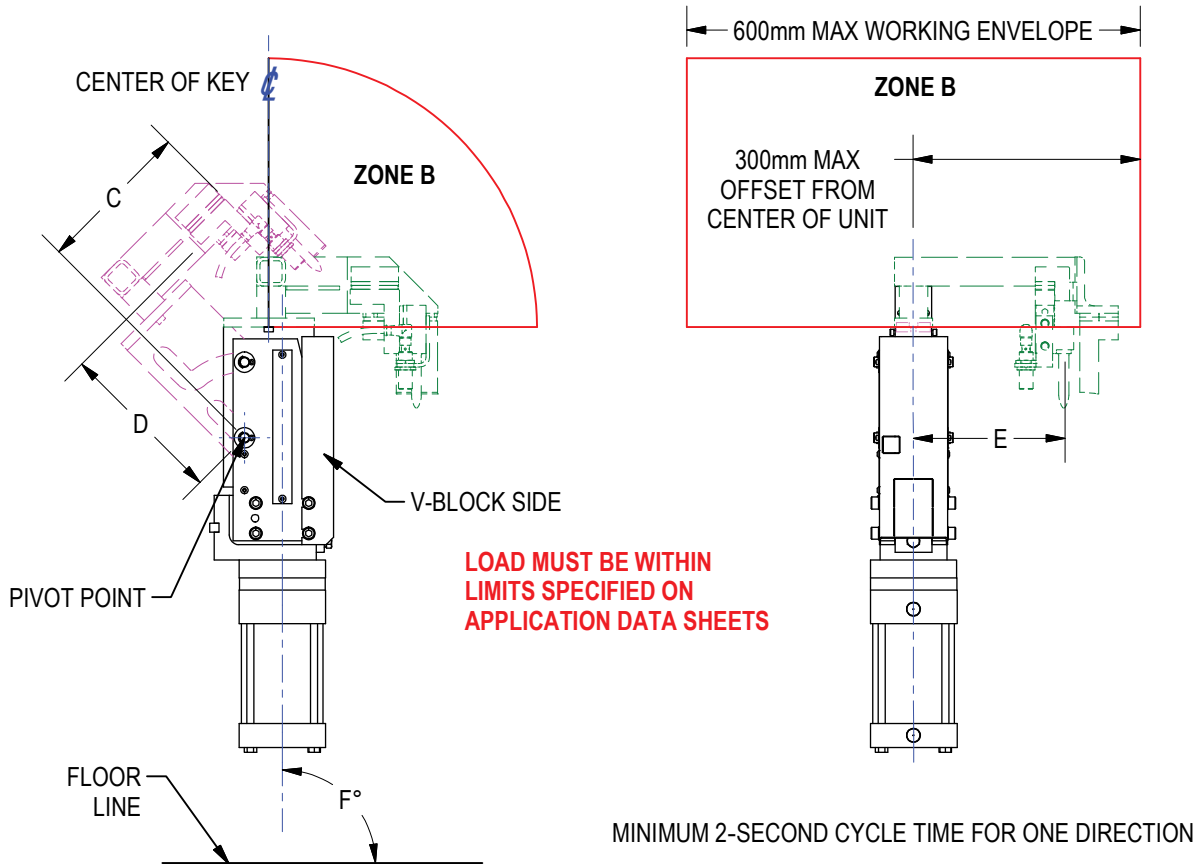

WELKER APPROVAL			
SUBMITTED BY		DATE	
PHONE NUMBER		EMAIL	
COMPANY NAME		PROGRAM	
WELKER APPROVAL BY		DATE	

ACTUATOR	EXTEND TORQUE	RETRACT TORQUE
70mm BORE CYLINDER	300in-lbf	225in-lbf
100mm BORE CYLINDER	600in-lbf	450in-lbf

(DO NOT SCALE DRAWING)

ENGINEERED PRODUCTS

(800) 229-0890 www.welkerproducts.com